



Commercial
RO Systems

CRO Series Reverse Osmosis Membrane Systems

Installation Instructions & Owner's Manual



aosmith.com/commercialwatertreatment

Table of Contents

System Requirements and Operation Guidelines	2
(Installation Instructions, Plumbing Connections, Electrical Connections)	
Installation and Startup Checklist	4
Membrane Specifications	5
System Identification	6
Startup Procedures	7
Operation and Maintenance	8
(Changing the Pre-filter, Membrane Installation, Removal and Replacement)	
Troubleshooting Guide	10
Electrical Drawings	11
Membrane Temperature Correction Chart	12
System Warranty	13



PLEASE READ THE ENTIRE MANUAL BEFORE PROCEEDING WITH THE INSTALLATION AND STARTUP. YOUR FAILURE TO FOLLOW ANY INSTRUCTIONS OR OPERATING PARAMETERS MAY LEAD TO THE PRODUCT'S FAILURE, WHICH CAN CAUSE PROPERTY DAMAGE AND/OR PERSONAL INJURY.

- DO NOT USE WHERE THE WATER IS MICRO-BIOLOGICALLY UNSAFE OR OF UNKNOWN QUALITY WITHOUT ADEQUATE DISINFECTION BEFORE OR AFTER THE SYSTEM.
- PRETREATMENT MUST BE SUFFICIENT TO ELIMINATE CHEMICALS THAT WOULD ATTACK THE MEMBRANE MATERIALS.
- ALWAYS TURN OFF THE UNIT, SHUT OFF THE FEED WATER, AND DISCONNECT THE ELECTRICAL POWER WHEN WORKING ON THE UNIT.
- NEVER ALLOW THE PUMP TO RUN DRY.
- NEVER START THE PUMP WITH THE CONCENTRATE VALVE CLOSED.
- NEVER ALLOW THE UNIT TO FREEZE OR OPERATE WITH A FEED WATER TEMPERATURE ABOVE 100°F.

Your A. O. Smith Commercial RO Series is a precision built, high quality product. These units will deliver quality drinking water for many years to come, when installed and operated properly. Please study this manual carefully and understand the cautions and notes before installing. This manual should be kept for future reference. If you have any questions regarding your system, contact your local dealer or the manufacturer at the following:

1900 Prospect Court • Appleton, WI 54914
Phone: 920-739-9401 • Fax: 920-739-9406

INSTALLATION INSTRUCTIONS:

For the installer, the following must be adhered to:

- Proper pretreatment must be determined and installed prior to the RO system.
- The water supply and pretreatment equipment should be sufficient to provide a minimum of 45 psi at the maximum feed flow.
- Responsibility for meeting local electrical and plumbing codes lies with the owner/operator.
- Install indoors in an area protected from freezing. Space allowances for the removal of the membranes from the pressure vessels should be provided.

PLUMBING CONNECTIONS:

NOTE: It is the responsibility of the end user to ensure that the installation is done according to local codes and regulations.

1. Connect the pre-treated feed water line to the inlet solenoid valve. A feed water shutoff valve should be located within 10 feet of the system.
2. Temporarily connect the product water outlet to a drain. The product outlet is located on the back top of the permeate flow meter.
3. Connect the concentrate water outlet to a drain. The concentrate outlet is located on the back top of the concentrate flow meter. The concentrate drain line should never be restricted. An air gap must be located between the end of the drain line and the drain. The use of a standpipe or other open drain satisfies most state and local codes and allows for visual inspection and sampling.

ELECTRICAL CONNECTIONS:

NOTE: It is the responsibility of the end user to ensure that the installation is done according to local codes and regulations.

1. Make sure the ON/OFF switch on the front panel is in the **“OFF”** position.
2. Wire the supplied 110V or 220 volt cord (dependent on system being installed) to a junction box power supply with a 20 amp breaker following local electrical codes.

Installation & Start-up Checklist

Please use the supplied checklists below to record the initial system hardware and site install conditions. Keep this copy for future reference. If you have additional systems to install, make a copy of this form first.

STARTUP INSTALL/CONDITIONS

Installation Date: _____

Installer Name: _____

Site of Install: _____

CRO System Model: _____

Water Source: _____

Pre-treatment Installed: yes no

If yes, explain: _____

FEED WATER ANALYSIS

TDS: Design _____ Startup _____

Turbidity: _____

Total Iron: _____

Chlorine: _____

Hardness: _____

Feed Water Temp: _____

Pre-filter cartridge model: _____

Starting pre-filter inlet pressure: _____

- Pressure at startup: _____

FLOW METER READINGS

• **Concentrate** Design _____ Startup _____

• **Recycle** Design _____ Startup _____

• **Permeate** Design _____ Startup _____

(Installer signature)

(date)

INSTALLATION CHECKLIST

Installation Address: _____

- Pre-treatment is installed and is flushed and working.
- Installation location allows access to membrane(s).
- Listed components and fittings are present.
- Loose components assembled to system.
- Membranes and pre-filter installed.
- System securely in place.
- Plumbing connections are complete.
- Initial flush without leaks.
- Electrical power connected, single phase. ___Volts ___Hz
- System sanitized.
- Controller display working.
- Proper operation is verified.
- All checks above have been completed.

INSTALLATION NOTES

500-8000 GPD – Membrane Specifications

OPERATING LIMITS:

Membrane Type	Polyamide Thin-Film Composite
Maximum Operating Temperature	100° F (38° C)
Maximum Operating Pressure	225 psi (15.5 bar) System Limits
pH Range, Continuous Operation*	2–11
pH Range, Short Term Cleaning (30 min)	1–13
Maximum Feed Silt Density Index	5
Chlorine Tolerance	0 ppm

*Maximum temperature for continuous operations above pH 10 is 95° F (35° C)

500–1,000 GPD HF4 Membrane - Product Specifications

Part Number	Description	Applied Pressure psi (bar)	Permeate Flow Rate gpd (m ³ /d)	Nominal Salt Rejection (%)	Membrane Quantities per GPD
200387	HF4 – 2521	100 (6.89)	400 (1.51)	99.0	500 GPD - 2 membranes
					1,000 GPD - 3 membranes

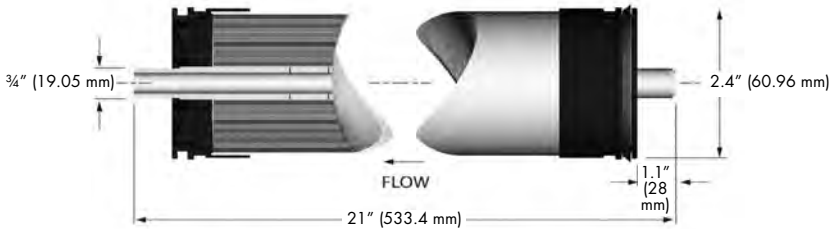

2,000–8,000 GPD HF5 Membrane - Product Specifications

Part Number	Description	Applied Pressure psi (bar)	Permeate Flow Rate PSI (gpd)	Applied Pressure psi (bar)	Permeate Flow Rate GPD (m ³ /d)	Nominal Salt Rejection (%)	Membrane Quantities per GPD
200394	HF5 – 4040	80 (5.52)	2500 (9.46)	100 (6.89)	3000 (11.36)	98.5	2,000 GPD - 1 membrane
							4,000 GPD - 2 membranes
							6,000 GPD - 3 membranes
							8,000 GPD - 4 membranes

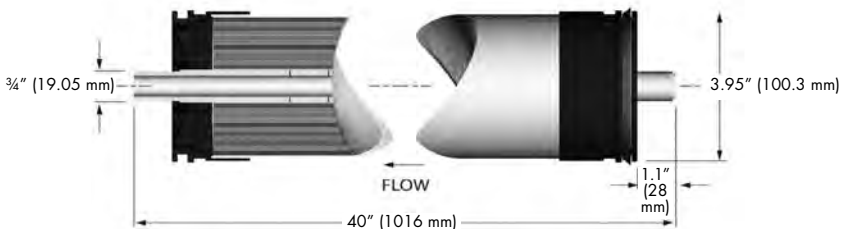

Under certain conditions, the presence of free chlorine and other oxidizing agents will cause premature membrane failure. Since oxidation damage is not covered under warranty, the manufacturer recommends removing residual free chlorine by pretreatment prior to membrane exposure. Wet tested membrane elements must be kept sealed and moist when in storage. Drying out may occur and damage the membrane permanently. Prevent elements from freezing or being exposed to direct sunlight. Wet tested elements are vacuum sealed in a polyethylene bag containing M100 Membrane Preservation and then packaged in a cardboard box. Discard the permeate for the first 24 hours of operation. The permeate flow (product water flow) varies with feed water temperature. For membrane warranty information, please contact the manufacturer.

The manufacturer believes the information and data contained herein to be accurate and useful. The information and data are offered in good faith, but without guarantee, as conditions and methods of use of products are beyond the manufacturer's control. The manufacturer assumes no liability for results obtained or damages incurred through the application of the presented information and data. It is the user's responsibility to determine the appropriateness of these products for the user's specific end uses.

System Identification

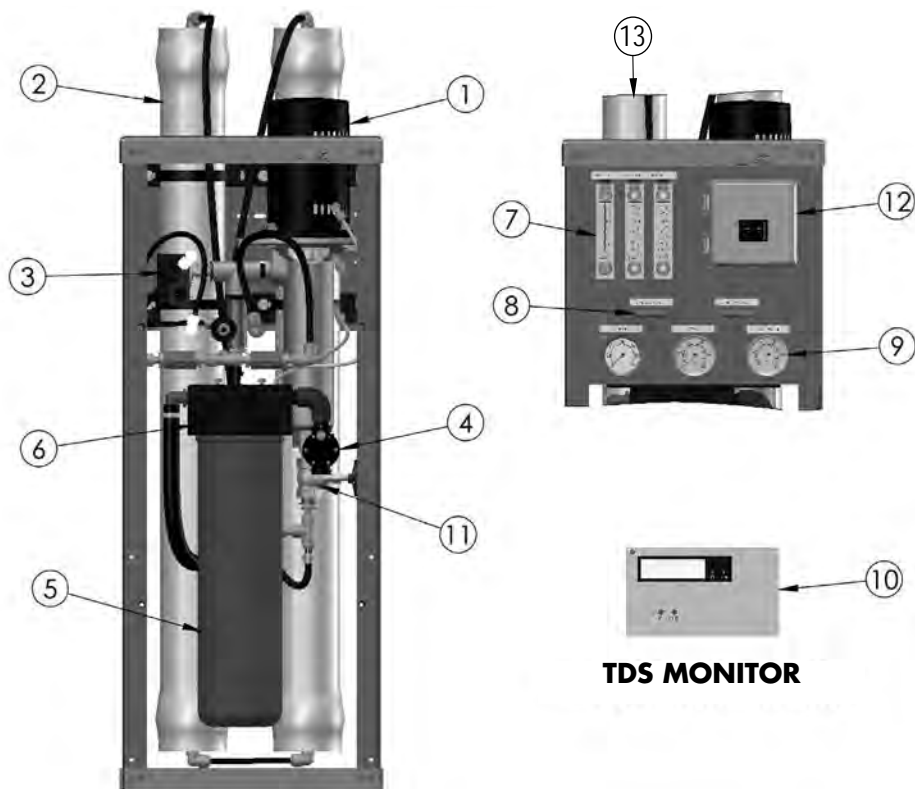

Models: CRO 500-8000

Item Number	Description	Part Number	Model
1	Pump, Multi-Stage, 3/4 HP, 110/220V, 1PH, C1, GOULDS	100394022	500-4000
1	Pump, Multi-Stage, 1.5 HP, 110/220V, 1PH, C1, GOULDS	100394021	6000-8000
2	Membrane, HF4, 2521, Dry (see page 5 for qty. requirements)	200387	500-1000
2	Membrane, HF5, 4040, Dry (see page 5 for qty. requirements)	200394	2000-8000
2	Upgrade Kit, 2521, includes housing, membrane, and end caps	207881	500-1000
2	Upgrade Kit, 4040, includes housing, membrane, and end caps	207842	2000-4000
3	Switch, Pressure, Low, N/O, 15-30 psi, 1/4" FNPT	200906	500-8000
4	Kit, Valve, Solenoid, 2-way, Composite, 120V, 3/4" FNPT, ASCO	210462	500-4000
4	Kit, Valve, Solenoid, 2-way, Composite, 220V, 3/4" FNPT, ASCO	210463	500-4000
5	Cartridge, Sediment, Polypro, 4.5" x 20", 5 MIC, SDC-45-2005	100243053	500-8000
6	O-Ring, Housing, Filter, Single, 4.5", Pentek	151122	500-8000
7	Meter, Flow, PM, 0.1-1 GPM, 1/2" MNPT x 1/2" MNPT	203849	500-1000
7	Meter, Flow, PM, 0.2-2 GPM, 1/2" MNPT x 1/2" MNPT	200897	2000
7	Meter, Flow, PM, 1-5 GPM, 1/2" MNPT x 1/2" MNPT	200898	4000-6000
7	Meter, Flow, PM, 1-5 GPM, 1/2" MNPT x 1/2" MNPT	200898	8000
7	Meter, Flow, PM, 1-10 GPM, 1" MNPT x 1" MNPT	200899	
8	Valve, Needle, SS 316L, 1/4" FNPT	201004	500-1000
8	Valve, Needle, SS 316L, 1/2" FNPT	201006	2000-8000
9	Gauge, PM, Gly Fill, 0-300 PSI/Bar, 2.5" Diameter MNPT	200904	500-8000
9	Gauge, PM, Gly Fill, 0-100 PSI/Bar, 2.5" Diameter MNPT	204165	500-8000
10	RO, HDM-2 TDS MONITOR, OEM	243088	500-8000
11	Valve, Globe, SS, 3/4" FNPT	200994	500-8000
12	Controller, RO, On/Off, C21	207818	500-8000
12	Controller, 2A, C23	207748	500-8000
13	End Cap, 2.5"	208904	500-1000
Not shown	O-Ring, EDPM, 2.5"	208909	500-1000
13	End Cap, 4"	209824	2000-8000
Not shown	O-Ring, EDPM, 4", FRP-300E	205896	2000-8000
Not shown	1/2" O-Ring, Membrane, 2.5" End Cap	208912	500-1000
Not shown	Black Check Valve, PP, Glass-filled	200965	500-8000

Start-up Procedures

PURGE:

1. Verify incoming pressure is between 40 and 70 psi.
2. Verify that the pretreatment equipment is installed and working properly. Pre-filtration must be flushed and sediment free.
3. Direct permeate water to drain temporarily.
4. Verify that the FLUSH/OFF/ON rocker switch is in the **"OFF"** position.
5. Fully open the concentrate valve (counter clockwise).
6. Fully close the concentrate recycle valve clockwise.
7. Fully open the globe valve on pump end (counter clockwise).
8. Slowly turn on feed water supply.
9. Re-verify incoming pressure is between 40 and 70 psi.
10. Push rocker switch to **"FLUSH"** mode to open solenoid (this is a momentary position).
11. Allow the unit to pressurize completely and check for any leaks, purge all the air out of the system and observe the concentrate flow meter for air to be expelled. Return rocker switch to **"OFF"** position.
12. Verify incoming pressure is between 40 and 70 psi on filter in gauge. Pressure reducing valve will be required if pressure is greater than 70.

INITIAL STARTUP:

1. Fully close globe valve on pump end (clockwise) then open one full revolution (counter clockwise).
2. Turn the rocker switch on the front panel to the **"ON"** position with the indicating green light lit.
3. System pump should turn on and boost pressure to the system.
4. Allow the unit to run for 30-60 minutes to flush the preservative from the membrane(s).

NOTE: Do not exceed 200 psi on the pump pressure gauge.

5. Adjust the concentrate, concentrate recycle valve, and globe valves until the desired flows are achieved.
6. Allow the product water to flow to drain for an additional 30-60 minutes.
7. Test and verify unit performance. Turn off the system and re-direct the product line to the point of use.
8. Restart the system and check for system leaks.

Operation & Maintenance

The reverse osmosis process causes the concentration of impurities. The impurities may precipitate (come out of solution) when their concentration reaches saturation levels.

NOTE: Precipitation can scale or foul membranes and must be prevented.

Check your feed water chemistry and pre-treat the water and/or reduce the system's recovery as required. If necessary, consult with your local dealer or distributor.

PRE-FILTER PRESSURE GAUGES:

These gauges measure the feed water pressure when it enters and exits the pre-filters. A pressure differential of 10-15 psi or more on the two pressure gauges indicates that the pre-filter requires servicing. For example, if the inlet pressure is 40 psi, the filter should be changed when the outlet pressure is 30 psi or below. **Failure to maintain filter will result in system damages.**

CHANGING THE PRE-FILTER:



WARNING: All pressure gauges must be read zero before proceeding. Before attempting, disconnect the power from the system and bleed all water pressure from the system.

The system comes with a standard 5 Micron Sediment Depth Filter that is located inside the filter housing.

1. To remove filter, turn the filter housing counterclockwise using the filter wrench supplied with system.
2. Once removed, replace sediment cartridge with similar size 5 micron sediment filter. Dispose of old filter properly. Check o-ring located at top of filter housing sump and re-lube or replace if necessary before re-installing on system. Re-install housing, turn **hand tight** (clockwise) and check for leaks after system is turned back on.

MEMBRANE INSTALLATION, REMOVAL AND REPLACEMENT:

Installing and replacing membranes in the pressure vessels is an easy process if you have the proper information and tools at hand. Please refer to the following instructions when removing and replacing membrane elements:



WARNING: All pressure gauges must be read zero before proceeding. Before attempting, disconnect the power from the system and bleed all water pressure from the system.

1. Remove the end plugs from the top of the pressure vessels. This is done by removing the two half-moon retaining disks using a #5 Allen wrench; the end plugs should then freely slide out of the pressure vessel.
2. Remove the replacement membrane element(s) from the shipping box; the membrane(s) should be contained within a plastic oxygen barrier bag.

NOTE: Wear gloves for the following steps in order not to contaminate the membrane.

3. Cut the bag open as close as possible to the seal at one end of the bag, so the bag may be re-used if necessary.

Operation & Maintenance

4. Remove membrane from bag. Make sure that all parts of the membrane are clean and free from dirt. Examine the brine seal and permeate tube for nicks or cuts. Replace the o-rings or brine seal if damaged.
5. Load membranes into pressure vessels according to the concentrate flow direction. Note the position of the brine seal placement on the membrane. Each housing has an arrow indicating the direction of flow for that housing. The brine seal must be at the water inlet of the housing.
6. Use Dow #7 silicone grease on the o-rings and brine seal before installing the membrane.
7. Install the new membrane in direction as shown in diagram:

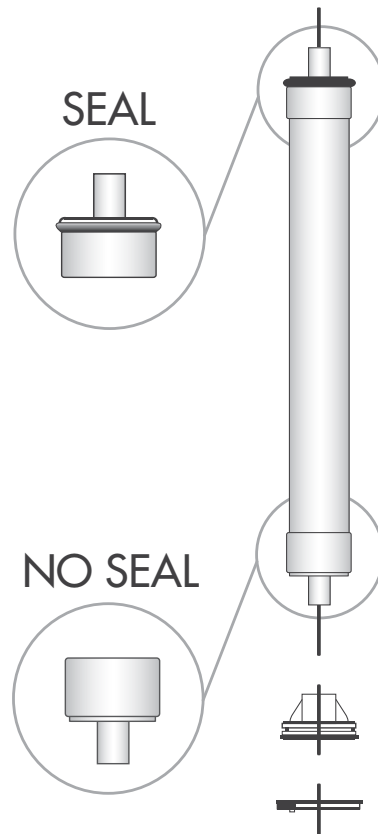

8. Once membrane has been fully inserted into vessel, re-install the black end plug, white snap ring, and yellow locking clip. (Ensure the white snap ring is fully seated all the way around the end plug.)
9. Change is complete.

Troubleshooting Guide

1. Low inlet pressure	A. Low supply pressure	A. Increase inlet pressure
	B. Cartridge filters plugged	B. Change filters
	C. Solenoid valve malfunction	C. Replace solenoid valve and/or coil
	D. Leaks	D. Fix any visible leaks
2. Low permeate flow	A. Low inlet flow	A. Adjust concentrate valve
	B. Cold feed water	B. See temperature correction sheet (<i>page 12</i>)
	C. Low operating pressure	C. See low inlet pressure
	D. Defective membrane brine seal	D. Inspect and/or replace brine seal
	E. Fouled or scaled membrane	E. Clean membranes
3. High permeate flow	A. Damaged product tube o-rings	A. Inspect and/or replace o-rings
	B. Damaged or oxidized membranes	B. Replace membrane
	C. Exceeding maximum feed water temperature	C. See temperature correction sheet (<i>page 12</i>)
4. Poor permeate quality	A. Low operating pressure	A. See low inlet pressure
	B. Damaged product tube o-rings	B. Inspect and/or replace o-rings
	C. Damaged or oxidized membranes	C. Replace membrane
5. Membrane fouling	A. Metal oxide fouling	A. Improve pretreatment for colloid removal. Clean with acid cleaners.
	B. Colloidal fouling	B. Optimize pretreatment for colloid removal. Clean with high pH anionic cleaners.
	C. Scaling (CaSO ₄ , CaSO ₃ , BaSO ₄ , SiO ₂)	C. Increase acid addition and antiscalent dosage for CaVO ₃ and CaCO ₄ . Reduces recovery. Clean with acid cleaners.
	D. Biological fouling	D. Shock dosage of Sodium Bisulfate. Continuous feed of Sodium Bisulfate at reduced pH. Chlorination and de-chlorination. Replace cartridge filters.
	E. Organic fouling	E. Activated carbon or other pretreatment. Clean with high pH cleaner.
	F. Chlorine oxidation	F. Check chlorine feed equipment and de-chlorination system.
	G. Abrasion of membrane by crystalline material	G. Improve pretreatment. Check all filters for media leakage.

Electrical Drawings – 120 Volt

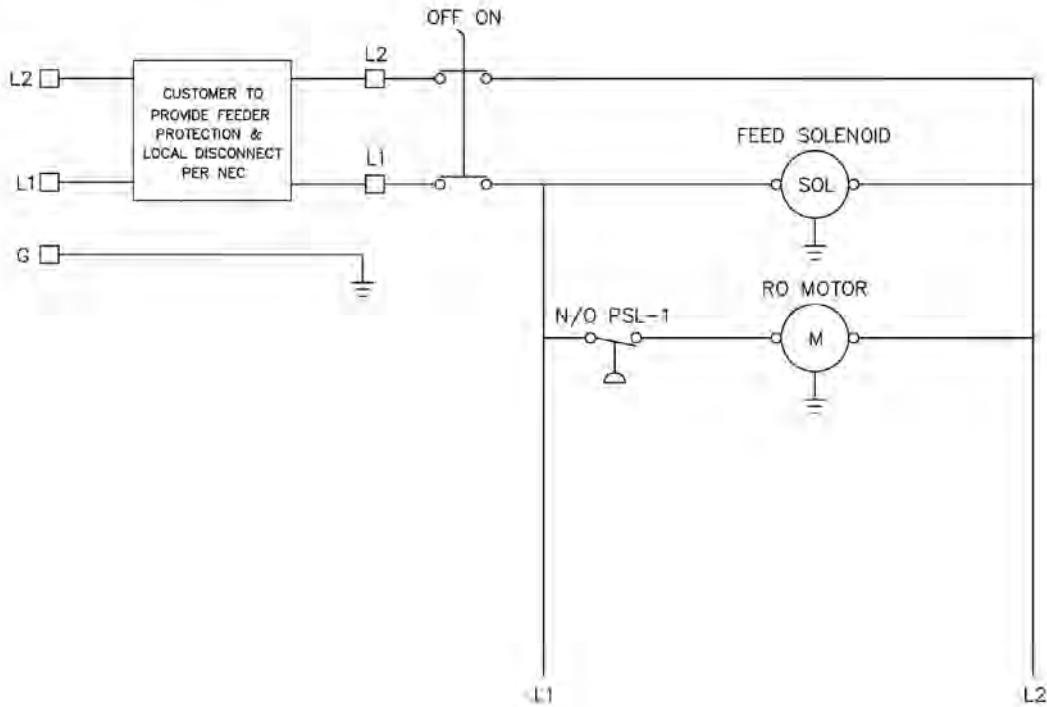
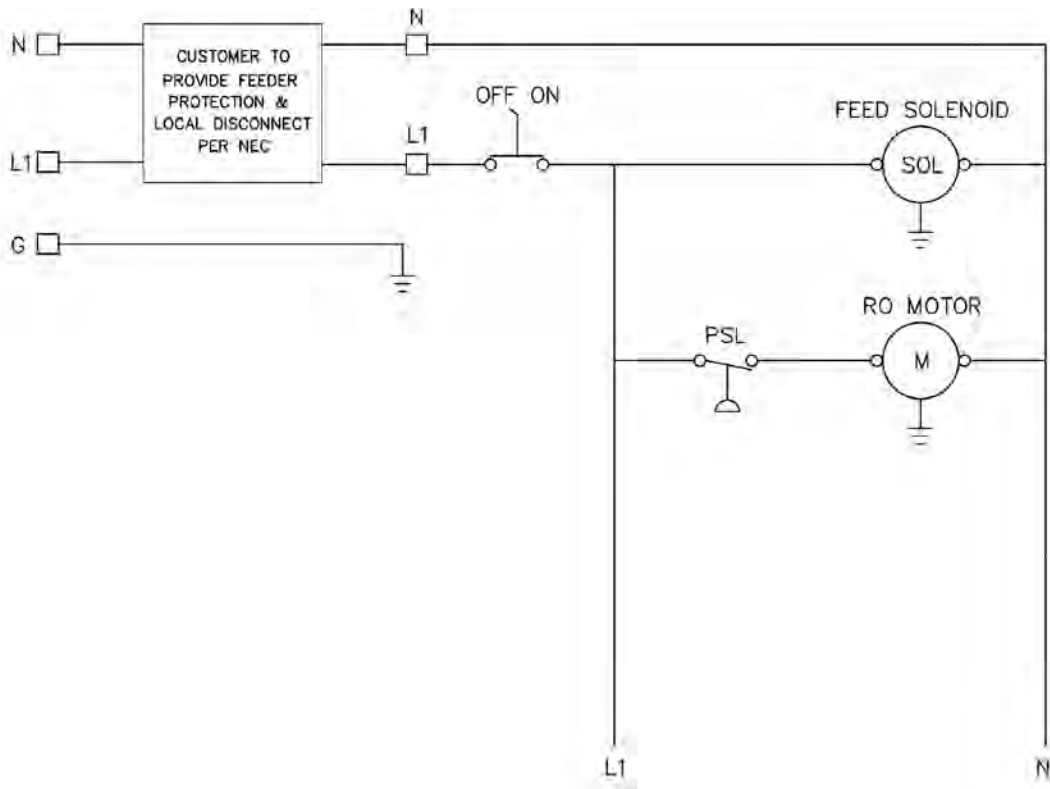

ELECTRICAL SYMBOLS				WIRE DESCRIPTION		WIRE GAUGE	
				MAIN POWER WIRES	14 AWG		
SOLENOID	MOTOR	GROUND	ON/OFF SWITCH	PUMP WIRES	14 AWG		
				SOLENOID WIRES	18 AWG		
N/O PRESSURE SWITCH	CHEMICAL PUMP OUTLET						
MISCELLANEOUS SYMBOLS							

Membrane Temperature Correction

Temperature °F (°C)	Temperature Correction Factor	Temperature °F (°C)	Temperature Correction Factor	Temperature °F (°C)	Temperature Correction Factor	Temperature °F (°C)	Temperature Correction Factor	Temperature °F (°C)	Temperature Correction Factor
50.0 (10.0)	1.711	57.2 (14.0)	1.475	64.4 (18.0)	1.276	71.6 (22.0)	1.109	78.8 (26.0)	0.971
50.2 (10.1)	1.705	57.4 (14.1)	1.469	64.6 (18.1)	1.272	71.8 (22.1)	1.105	79.0 (26.1)	0.968
50.4 (10.2)	1.698	57.6 (14.2)	1.464	64.8 (18.2)	1.267	72.0 (22.2)	1.101	79.2 (26.2)	0.965
50.5 (10.3)	1.692	57.7 (14.3)	1.459	64.9 (18.3)	1.262	72.1 (22.3)	1.097	79.3 (26.3)	0.962
50.7 (10.4)	1.686	57.9 (14.4)	1.453	65.1 (18.4)	1.258	72.3 (22.4)	1.093	79.5 (26.4)	0.959
50.9 (10.5)	1.679	58.1 (14.5)	1.448	65.3 (18.5)	1.254	72.5 (22.5)	1.090	79.7 (26.5)	0.957
51.1 (10.6)	1.673	58.3 (14.6)	1.443	65.5 (18.6)	1.249	72.7 (22.6)	1.086	79.9 (26.6)	0.954
51.3 (10.7)	1.667	58.5 (14.7)	1.437	65.7 (18.7)	1.245	72.9 (22.7)	1.082	80.1 (26.7)	0.951
51.4 (10.8)	1.660	58.6 (14.8)	1.432	65.8 (18.8)	1.240	73.0 (22.8)	1.078	80.2 (26.8)	0.948
51.6 (10.9)	1.654	58.8 (14.9)	1.427	66.0 (18.9)	1.236	73.2 (22.9)	1.075	80.4 (26.9)	0.945
51.8 (11.0)	1.648	59.0 (15.0)	1.422	66.2 (19.0)	1.232	73.4 (23.0)	1.071	80.6 (27.0)	0.943
52.0 (11.1)	1.642	59.2 (15.1)	1.417	66.4 (19.1)	1.227	73.6 (23.1)	1.067	80.8 (27.1)	0.940
52.2 (11.2)	1.636	59.4 (15.2)	1.411	66.6 (19.2)	1.223	73.8 (23.2)	1.064	81.0 (27.2)	0.937
52.3 (11.3)	1.630	59.5 (15.3)	1.406	66.7 (19.3)	1.219	73.9 (23.3)	1.060	81.1 (27.3)	0.934
52.5 (11.4)	1.624	59.7 (15.4)	1.401	66.9 (19.4)	1.214	74.1 (23.4)	1.056	81.3 (27.4)	0.932
52.7 (11.5)	1.618	59.9 (15.5)	1.396	67.1 (19.5)	1.210	74.3 (23.5)	1.053	81.5 (27.5)	0.929
52.9 (11.6)	1.611	60.1 (15.6)	1.391	67.3 (19.6)	1.206	74.5 (23.6)	1.049	81.7 (27.6)	0.926
53.1 (11.7)	1.605	60.3 (15.7)	1.386	67.5 (19.7)	1.201	74.7 (23.7)	1.045	81.9 (27.7)	0.924
53.2 (11.8)	1.600	60.4 (15.8)	1.381	67.6 (19.8)	1.197	74.8 (23.8)	1.042	82.0 (27.8)	0.921
53.4 (11.9)	1.594	60.6 (15.9)	1.376	67.8 (19.9)	1.193	75.0 (23.9)	1.038	82.2 (27.9)	0.918
53.6 (12.0)	1.588	60.8 (16.0)	1.371	68.0 (20.0)	1.189	75.2 (24.0)	1.035	82.4 (28.0)	0.915
53.8 (12.1)	1.582	61.0 (16.1)	1.366	68.2 (20.1)	1.185	75.4 (24.1)	1.031	82.6 (28.1)	0.913
54.0 (12.2)	1.576	61.2 (16.2)	1.361	68.4 (20.2)	1.180	75.6 (24.2)	1.028	82.8 (28.2)	0.910
54.1 (12.3)	1.570	61.3 (16.3)	1.356	68.5 (20.3)	1.176	75.7 (24.3)	1.024	82.9 (28.3)	0.908
54.3 (12.4)	1.564	61.5 (16.4)	1.351	68.7 (20.4)	1.172	75.9 (24.4)	1.021	83.1 (28.4)	0.905
54.5 (12.5)	1.558	61.7 (16.5)	1.347	68.9 (20.5)	1.168	76.1 (24.5)	1.017	83.3 (28.5)	0.902
54.7 (12.6)	1.553	61.9 (16.6)	1.342	69.1 (20.6)	1.164	76.3 (24.6)	1.014	83.5 (28.6)	0.900
54.9 (12.7)	1.547	62.1 (16.7)	1.337	69.3 (20.7)	1.160	76.5 (24.7)	1.010	83.7 (28.7)	0.897
55.0 (12.8)	1.541	62.2 (16.8)	1.332	69.4 (20.8)	1.156	76.6 (24.8)	1.007	83.8 (28.8)	0.894
55.2 (12.9)	1.536	62.4 (16.9)	1.327	69.6 (20.9)	1.152	76.8 (24.9)	1.003	84.0 (28.9)	0.892
55.4 (13.0)	1.530	62.6 (17.0)	1.323	69.8 (21.0)	1.148	77.0 (25.0)	1.000	84.2 (29.0)	0.889
55.6 (13.1)	1.524	62.8 (17.1)	1.318	70.0 (21.1)	1.144	77.2 (25.1)	0.997	84.4 (29.1)	0.887
55.8 (13.2)	1.519	63.0 (17.2)	1.313	70.2 (21.2)	1.140	77.4 (25.2)	0.994	84.6 (29.2)	0.884
55.9 (13.3)	1.513	63.1 (17.3)	1.308	70.3 (21.3)	1.136	77.5 (25.3)	0.991	84.7 (29.3)	0.882
56.1 (13.4)	1.508	63.3 (17.4)	1.304	70.5 (21.4)	1.132	77.7 (25.4)	0.988	84.9 (29.4)	0.879
56.3 (13.5)	1.502	63.5 (17.5)	1.299	70.7 (21.5)	1.128	77.9 (25.5)	0.985	85.1 (29.5)	0.877
56.5 (13.6)	1.496	63.7 (17.6)	1.294	70.9 (21.6)	1.124	78.1 (25.6)	0.982	85.3 (29.6)	0.874
56.7 (13.7)	1.491	63.9 (17.7)	1.290	71.1 (21.7)	1.120	78.3 (25.7)	0.979	85.5 (29.7)	0.871
56.8 (13.8)	1.486	64.0 (17.8)	1.285	71.2 (21.8)	1.116	78.4 (25.8)	0.977	85.6 (29.8)	0.869
57.0 (13.9)	1.480	64.2 (17.9)	1.281	71.4 (21.9)	1.112	78.6 (25.9)	0.974	85.8 (29.9)	0.866

$^{\circ}\text{F} = (^{\circ}\text{C} \times 9/5) + 32$

Corrected Flow Rate = (Measured Flow Rate) * (TCF @ Feed Water Temp.)

A. O. Smith Commercial Limited Warranty

WHO IS COVERED

This limited warranty is provided by A. O. Smith and applies only to the original owner who purchased and installed the A. O. Smith product for use at the original installation site. This warranty is non-transferable.

WHAT IS COVERED

This warranty covers defects in materials or workmanship in your A. O. Smith product when properly installed, used under normal operating conditions, and maintained according to A. O. Smith guidelines and local plumbing codes.

WARRANTY COVERAGE PERIODS

All warranty coverage periods run from the date of purchase, or 60 days after the date of manufacture if the purchase date cannot be verified.

For a period of ONE YEAR: The entire reverse osmosis water system, including the reverse osmosis modules, with the exception of the expendable filter cartridges used in the system.

WHAT A. O. SMITH WILL DO

If a component is found defective during its warranty period, A. O. Smith will repair or replace the defective part at its discretion with an identical part or a comparable part if an identical replacement is not available. The owner is responsible for freight charges from the factory and local dealer service or labor fees. The warranty period for any replacement will run for the balance of the original warranty period.

WHAT A. O. SMITH WILL NOT DO

A. O. Smith will not pay for labor to remove or reinstall parts, shipping damage, water damage resulting from system failure, dealer trip charges, unauthorized service, damage caused by failure to follow installation instructions, or replacement filters, media, or routine maintenance.

WHAT IS NOT COVERED

1. This warranty does not cover: damage caused by accident, misuse, neglect, fire, flood, freezing, or other acts of God, improper installation, alteration, vacuum damage, chemicals, operation outside specifications, cosmetic issues, non-A. O. Smith parts, installation costs, improper plumbing connections, lack of maintenance, use with water that is microbiologically unsafe, loss of use, property damage, incidental or consequential damages, freight, or water damage. A. O. Smith disclaims all implied warranties to the fullest extent permitted by law.
2. Except when specifically prohibited by the applicable state law, the Owner, and not the Manufacturer, shall be liable for and shall pay for all charges for labor or other expenses incurred in the removal, repair or replacement of any component part(s) claimed to be defective or any expense incurred to remedy any defect in the product. Such charges may include, but are not necessarily limited to:
 - a. All freight, shipping, handling and delivery costs of forwarding a new component or replacement part(s) to the owner.
 - b. All costs necessary or incidental in removing the defective component part(s) and installing a new component part(s).
 - c. Any material required to complete, and/or permits required for, installation of a new component or replacement part(s).
 - d. All costs necessary or incidental in returning the defective component part(s) to a location designated by the Manufacturer.
 - e. This warranty provides specific legal rights and limitations, but you may have other rights under applicable state law.

OWNER RESPONSIBILITIES

Owners must install and operate the system per A. O. Smith specifications, comply with local codes, prevent freezing or vacuum damage, operate within pressure/temperature limits, replace media/filters as required, use only approved components, and retain proof of purchase and installation date. Either proof of purchase from an authorized dealer or proof of serial number, along with proof of proper installation, will be required to obtain warranty coverage.

HOW TO OBTAIN SERVICE

If service is required, contact your installation dealer or an authorized A. O. Smith dealer. If unavailable, ship the defective component (freight prepaid) to: **A. O. Smith, 1000 Prospect Ct., Appleton, WI 54914**. A. O. Smith will return repaired or replaced parts freight collect. Registration is not required to be covered by this warranty.

LIMITATION OF REMEDIES

The owner's sole remedy is repair or replacement of defective parts. A. O. Smith is not liable for incidental, consequential, water, or property damages. Some states do not allow such limitations; in such states, these may not apply.

STATE LAW RIGHTS

This warranty provides specific legal rights; additional rights may vary by state.



1900 Prospect Court • Appleton, WI 54914
Phone: 920-739-9401 • Fax: 920-739-9406

